

CC100

Craft ROBO

User's Manual

MANUAL NO.CC100m-UM-152



GRAPHTEC

PREFACE

Thank you for purchasing the Craft ROBO CC100. Based on cutting-plotter technology developed by Graphtec over many years, CC 100 provides outstanding flexibility in operation. It can be used for cutting heavy-cardstock, paper and sticker film as well as pen plotting. Please read this manual thoroughly and assure proper use of the equipment.

Warning

Only computers or peripherals (computer input/output devices, terminals, printers, etc.) certified as complying with the limits for a Class B digital device, pursuant to Part 15 of the FCC Rules, may be attached to this product when this product is operated in a residential environment. Operation with non-certified peripherals is likely to result in interference to radio and TV.

Federal Communications Commission Radio Frequency Interference Statement

“This equipment has been tested and found to comply with the limits for a Class B digital device pursuant to Part 15 of the FCC Rules. These limits are designed to provide reasonable protection against harmful interference in a residential installation. This equipment generates, uses, and can radiate radio frequency energy and, if not installed and used in accordance with the instructions, may cause harmful interference to radio communications. However, there is no guarantee that interference will not occur in a particular installation. If this equipment does cause harmful interference to radio or television reception, which can be determined by turning the equipment off and on, the user is encouraged to try to correct interference by one or more of the following measures:

- Reorient or relocate the receiving antenna.
- Increase the separation between the equipment and receiver.
- Connect the equipment into an outlet on a circuit different from that to which the receiver is connected.
- Consult the dealer or an experienced radio/TV technician for help.”

Notes on this Manual

- (1) No part of this publication may be reproduced, stored in a retrieval system, or transmitted, in any form or by any means, without the prior written permission of Graphtec Corporation.
- (2) The product specifications and other information in this manual are subject to change without notice.
- (3) While every effort has been made to provide complete and accurate information, please contact your sales representative or nearest Graphtec vendor if you find any unclear or erroneous information or wish to make other comments or suggestions.
- (4) Notwithstanding the stipulations in the preceding paragraph, Graphtec Corporation assumes no liability for damages resulting from either the use of the information contained herein or the use of the product.

Registered Trademarks

All names of companies, brands, logotypes, and products appearing in this manual are the trademarks or registered trademarks of their respective companies.

Copyright

This User's Manual is copyrighted by Graphtec Corporation.

CONTENTS

PREFACE...../

 Warning...../

 Federal Communications Commission Radio Frequency Interference Statement...../

 Notes on this Manual/

 Registered Trademarks...../

 Copyright...../

CONTENTS...../

CHAPTER 1. PRIOR TO USE

1.1 Check all the items..... 1-1

1.2 Craft ROBO Parts and Functions..... 1-2

 Craft ROBO (CC100) 1-2

CHAPTER 2. CONNECTION AND PREPARATION

2.1 Connecting the Power Adapter 2-1

2.2 Connecting to a Computer 2-1

2.3 Loading Media..... 2-2

 Loading Method 2-2

 When the Media warps up 2-3

 Media Size 2-3

 Cutting area..... 2-4

 Using the carrier sheet..... 2-5

 Using a Carrier Sheet for smaller than Letter Size media 2-5

 Using a Carrier Sheet for Letter Size media 2-6

 Cutting area of the carrier sheet 2-7

2.4 Setting the Blade Length..... 2-8

 Blade holder description..... 2-8

 Blade adjustment caps and media selection..... 2-9

 Changing the blade adjustment caps..... 2-9

 Installing the blade holder 2-10

 Ballpoint pen installation 2-11

 Installing the ballpoint pen..... 2-12

CHAPTER 3. CRAFT ROBO CONTROLLER

3.1 The Craft ROBO Controller 3-1

3.2 Operating Environment 3-1

3.3 Installing the Craft ROBO Controller..... 3-2

 Starting up the Start window 3-2

 Installing the Controller 3-3

3.4 Using the Craft ROBO Controller..... 3-5

 Starting up the Craft ROBO Controller..... 3-5

 Cutter Operation..... 3-8

3.5 Craft ROBO Controller Components..... 3-11

3.6 Messages..... 3-23

Appendix A. Standard Specifications Appendix-1

INDEX..... Index1

CHAPTER 1. PRIOR TO USE

1.1 Check all the items

Referring to the list below, check to confirm that all components are included with your product. If any item is missing, please contact your place of purchase.

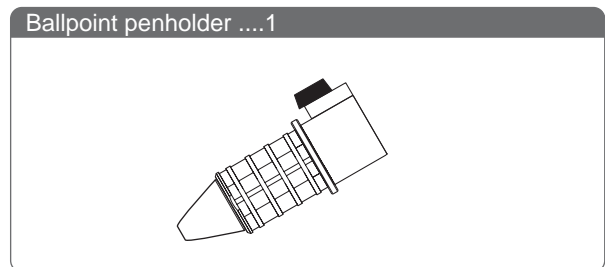
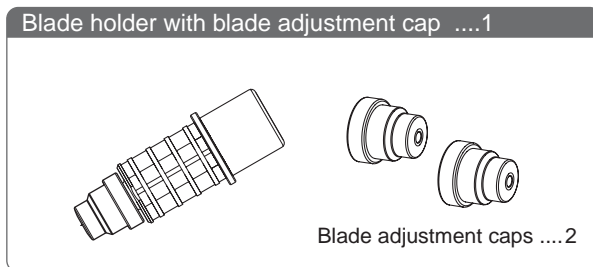
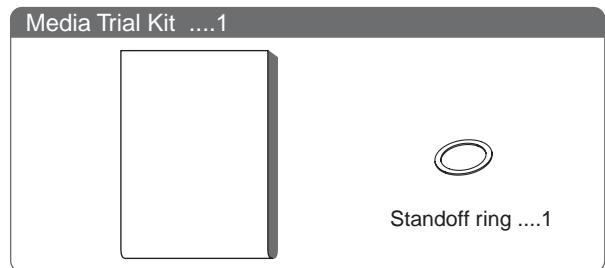
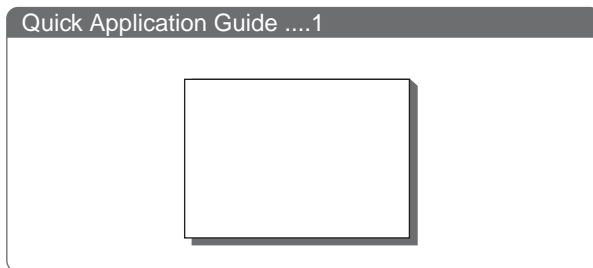
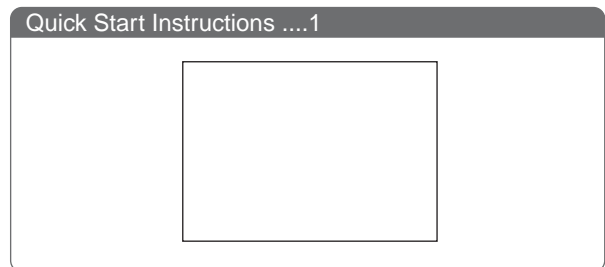
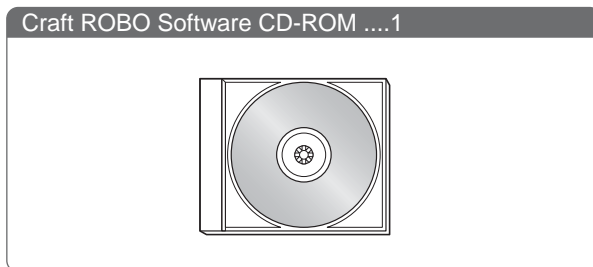
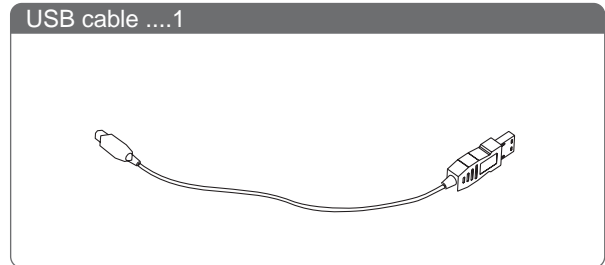
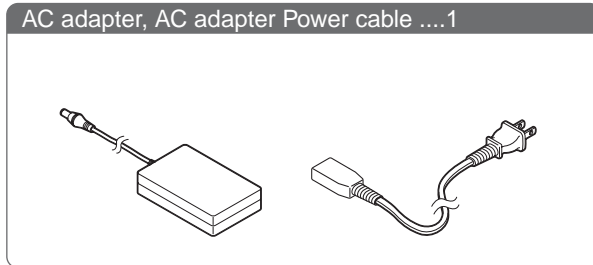

1.2 Craft ROBO Parts and Functions

Craft ROBO (CC100)

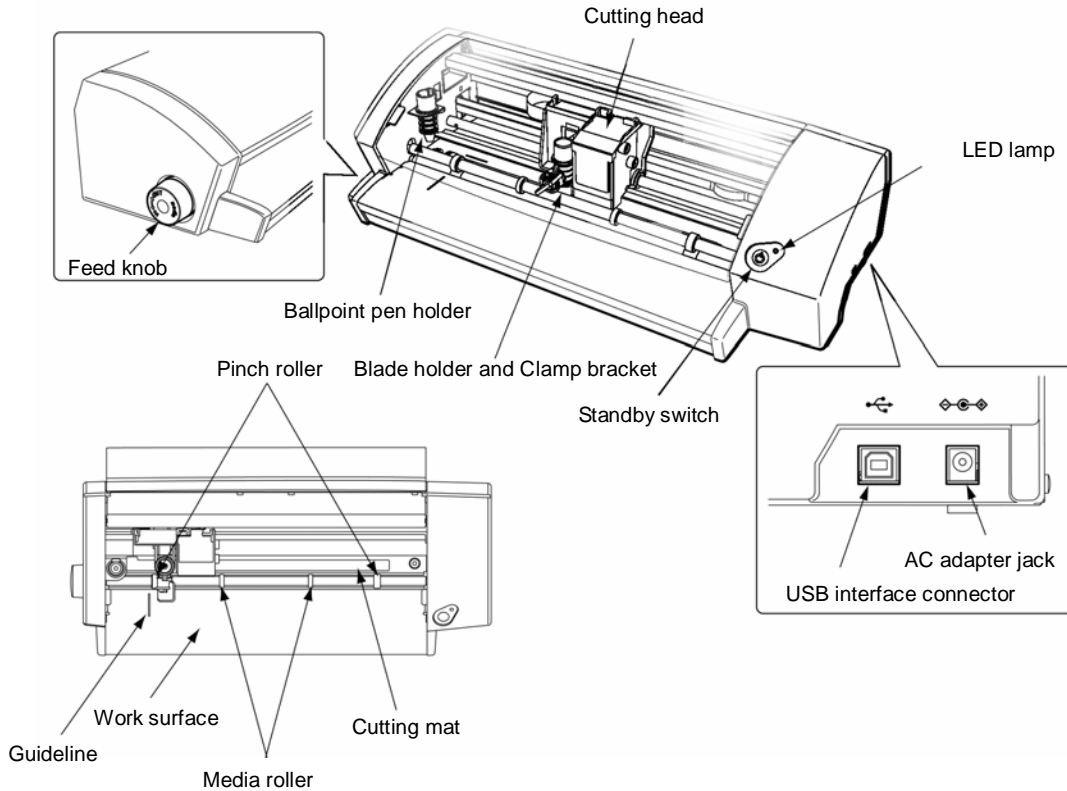

- Feed knob** Manually feeds media in and out
- Cutting Head** Drives the blade holder to the left or right
- Ballpoint penholder** Used for plotting using a ballpoint pen
- Blade holder** Used for cutting using a blade
- Clamp bracket** Holds the blade holder/penholder and drives it up or down
- Standby switch** Turns on and off the cutter
- LED lamp** The light is on when unit is ready to operate and flashes when data is received
- USB interface connector**... Used for connecting USB cable
- AC adapter jack** Used for connecting AC/DC power adapter cable
- Pinch roller** White rollers that tightly holds media in place, assuring accurate operation
- Guideline** Used as a guide when media is loaded in
- Work surface** Used for media support and alignment
- Media roller** Prevents media from warping
- Cutting mat** A black strip that protects work surface from damage caused by the blade

CHAPTER 2. CONNECTION AND PREPARATION

2.1 Connecting the Power Adapter

Connect the AC adapter jack of the cutter to the AC outlet of the rated voltage using the AC adapter included with the Craft ROBO and turn on the power.

Note Always connect to the AC adapter jack before connecting to the AC outlet.

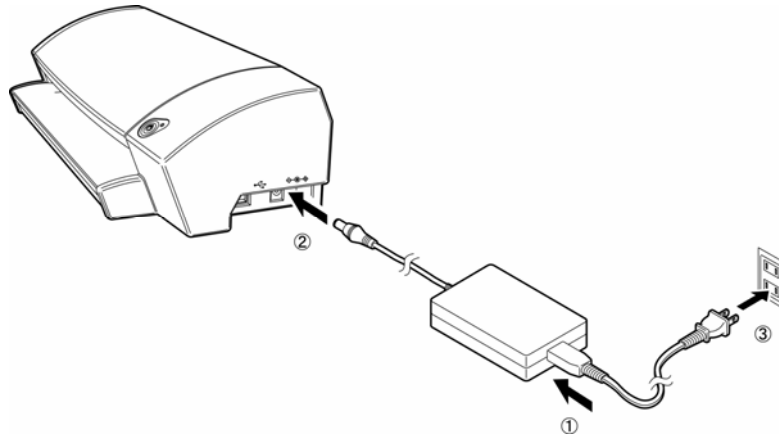

1. Connect the power cable (included with the AC adapter) to the AC adapter.
2. Plug the AC adapter cable into the AC adapter jack of the cutter.
3. Plug the other end of the power cable into the AC outlet.

2.2 Connecting to a Computer

Connect the cutter to a computer via USB cable.

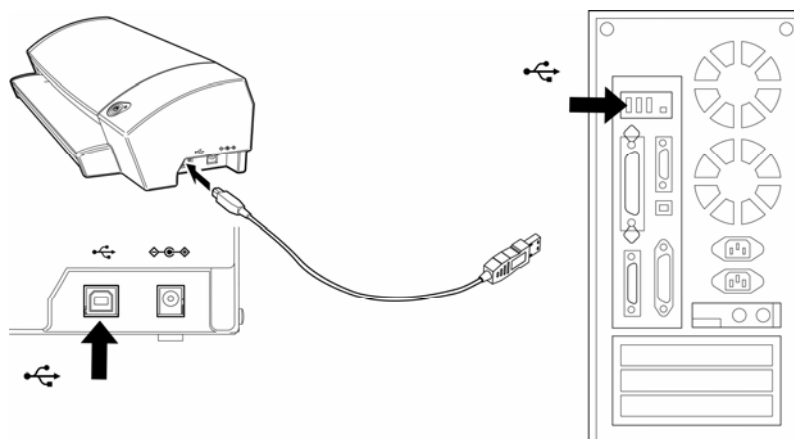

Use a USB cable to connect the cutter to a computer. The USB cable has different plug shapes on the computer side and the main-unit side. Always check which plug connects to which side.

Note Do not connect two or more units of the Craft ROBO to one computer. Do not connect the Craft ROBO and a Graphtec plotter to a computer at the same time. Otherwise, the Craft ROBO may not operate properly.

2.3 Loading Media

Loading Method



Do not load media without a backing sheet or carrier sheet, or perform a cutting operation when there is no media; either will damage the cutting mat.

1. Press the standby switch, and confirm that the LED lamp is lit.
2. If there is a loading direction printed on the sheet, load the sheet to the Craft ROBO accordingly.

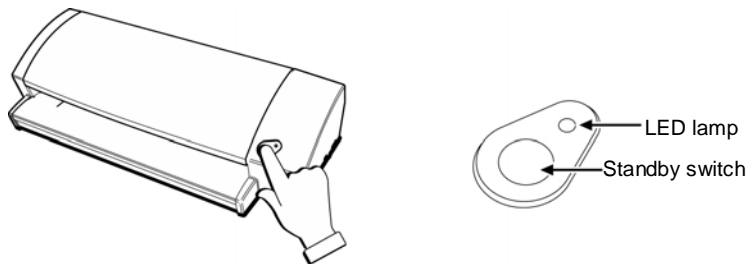

3. While making sure the media is straight, align the left edge of the sheet with the guideline.

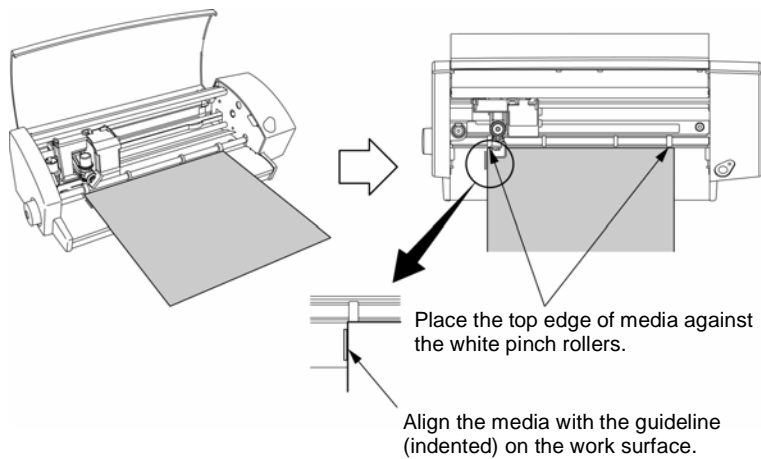

4. Turn the feed knob counterclockwise (away from you) and feed the sheet until it is aligned with the top edge of the black cutting mat.

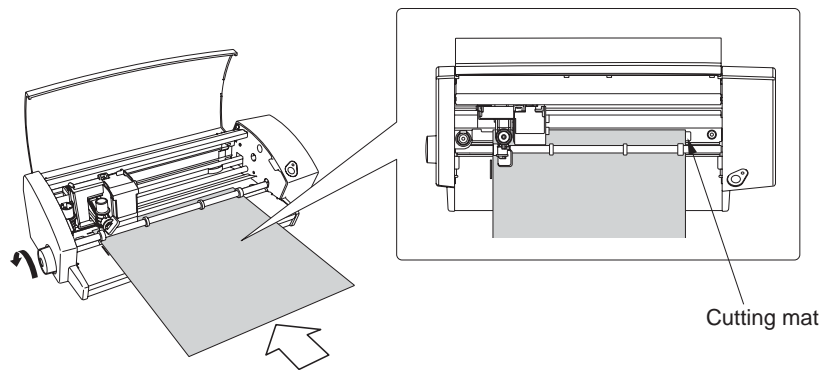

When the Media warps up

If the leading edge of the media is warped up and interferes with the blade tip, continue to feed the media until it aligns with the indented guideline located behind the cutting mat. This allows the media to feed properly but reduces the potential cutting area by 5 mm in the feed direction.

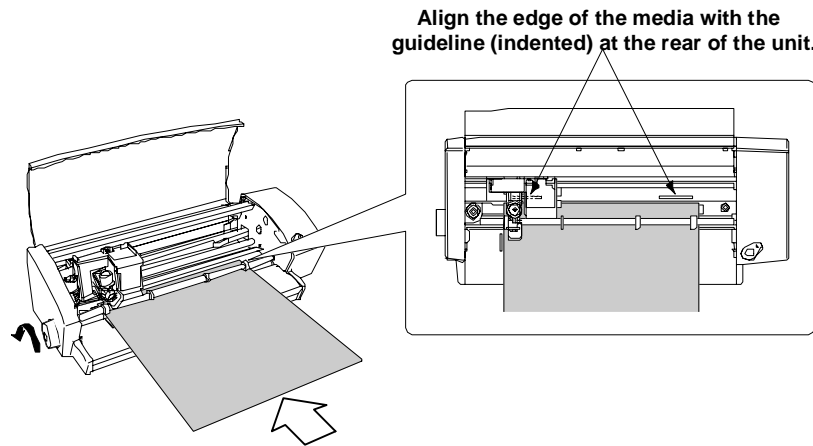

Media Size

Vinyl and medium that already have backing sheets (liners) can be between 210 and 260 mm in width and up to 1000 mm in length. Scraps of media without backing sheets (liners), starting from 100 mm in width, can be placed on the carrier sheet provided with the cutter.

Cutting area

Available cutting area is shown in the diagram below. In addition, make sure that media edges are parallel with the cutting guideline.

The possible cutting area varies with the mode you select.

In standard mode the cutting area is 190 mm in width.

In expanded mode the cutting area is 200 mm in width.

If registration marks are used the cutting area is 190 mm in width.

Note  The above numbers are true only when media is loaded correctly along the guideline.

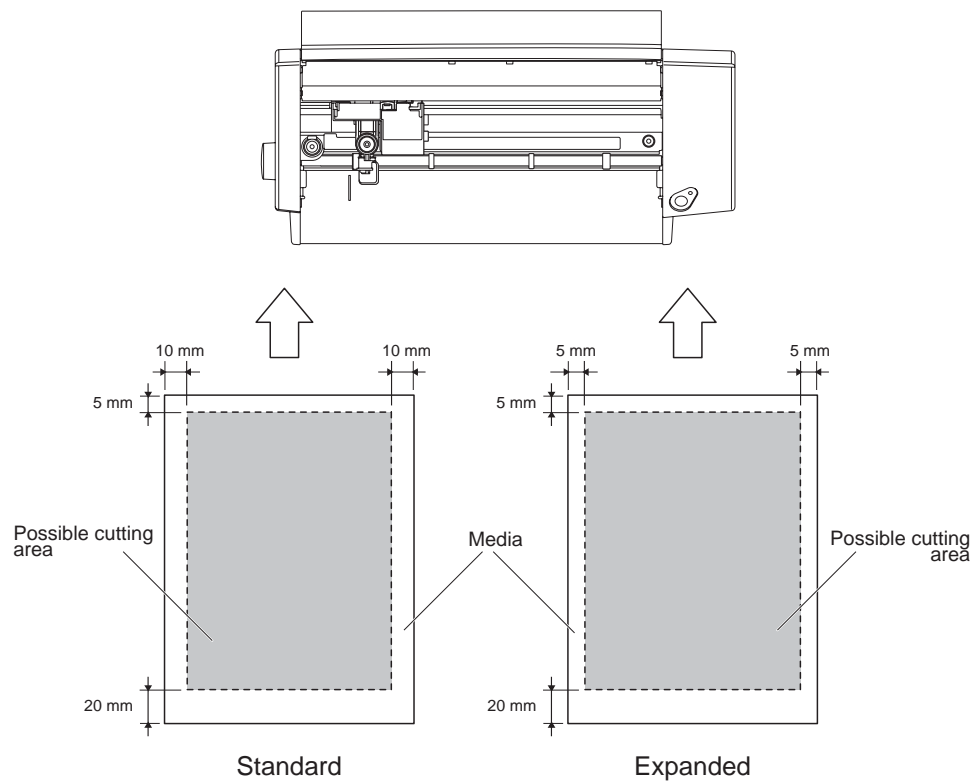

Using the carrier sheet

The carrier sheet allows media smaller than Letter size and media without a backing sheet (liner) to be cut.

Note

- For cutting out the media, always be sure to use the carrier sheet.
- The carrier sheet is removable, so can be used repeatedly. When its adhesive power becomes weak, however, replace it with a new carrier sheet.
- The carrier sheet is a consumable. Replace it after cutting approximately 10 sheets. Using a carrier sheet for more than 10 sheets may cause misaligned cutting or other problems. Actual number may vary depending on a type of cut media.
- Pulling out the carrier sheet without turning the feed knob may shorten its life, causing misaligned cutting. Always be sure to turn the feed knob to remove the media.

Using a Carrier Sheet for smaller than Letter Size media

Note

Do not use media smaller than 100 mm.

1. Peel off only the inside liner of the carrier sheet, so that the adhesive surface is visible. (When using the carrier sheet, do not peel off the liner strips on both sides.)

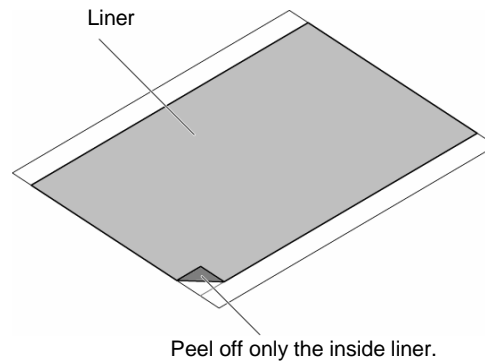

2. Press the media onto the adhesive surface of the carrier sheet.

Note

When pressing the media, be careful not to cause air bubbles or wrinkles in the media.

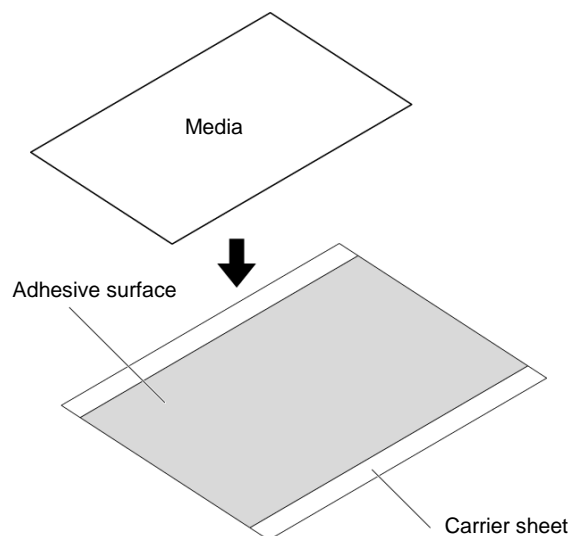

Using a Carrier Sheet for Letter Size media



Do not use media larger than 210 mm in width.

1. Peel off the liner inside and on both sides of the carrier sheet, so that the adhesive surface is visible.

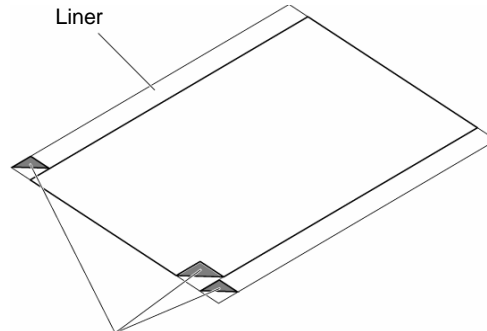

Peel off the liner inside and on both sides of the backing sheet.

2. Press the media onto the adhesive surface of the carrier sheet, making sure that the edges of the media are aligned with the carrier sheet.



When pressing the media, be careful not to cause air bubbles or wrinkles in the media.

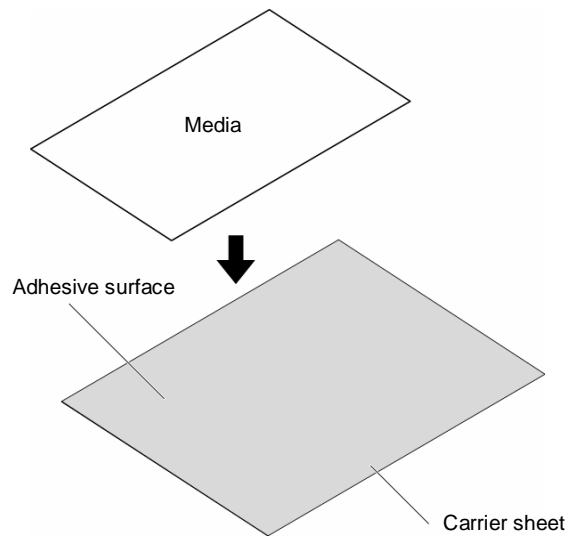

Cutting area of the carrier sheet

The available cutting area of the carrier sheet is shown in the diagram below. When using media smaller than Letter size, always place the media within the cutting area. In addition, make sure the media is set parallel to the edges of the carrier sheet.

Note  Do not use media smaller than 100 mm.

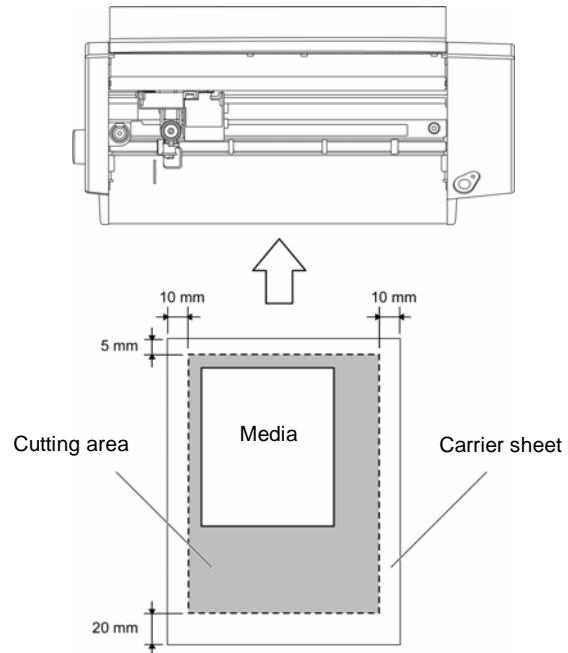

2.4 Setting the Blade Length

Blade adjustment cap controls the blade length. To obtain better cutting results, select the blade adjustment cap of the blade holder according to the type of media to be cut.



The length of the blade protruding from the cap should not exceed the thickness of the media, otherwise the cutting mat may be damaged.



Caution When handling the cutter blade, exercise care to prevent injuring your hand.



Blade holder description

The length of the blade protruding from the cap can be adjusted by selecting one of the three available blade adjustment caps.

Select the blade adjustment cap best suited for the media in use. Always perform a test cut to assure proper blade length.

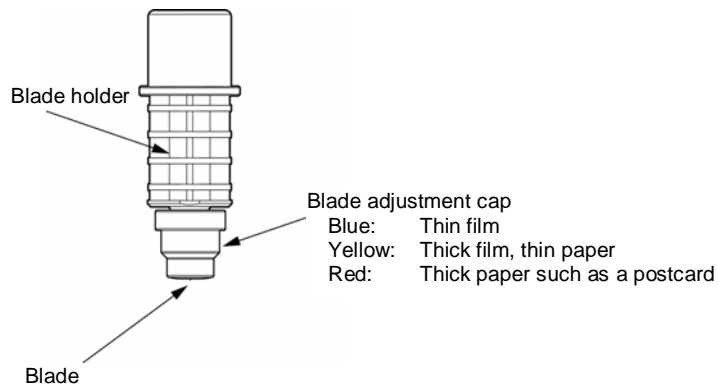

Blade adjustment caps and media selection

Select and set the blade adjustment cap best suited to the media in use

Selection guide for blade adjustment caps

Cap	Media
Blue	Thin film
Yellow	Thick film, thin media
Red	Thick media

Changing the blade adjustment caps

The blade adjustment cap is a screw-on type.

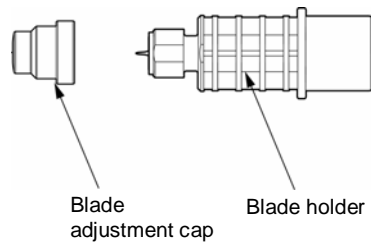

1. Turn it in the counterclockwise direction to remove the cap.
2. Replace with the correct blade adjustment cap.
3. Turn it in the clockwise direction to tighten the cap.

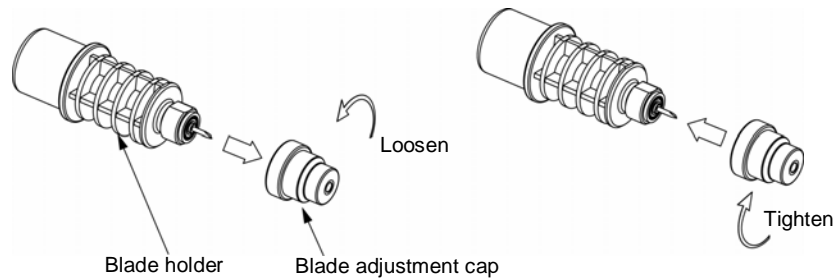

Installing the blade holder

Insert the blade holder that has had its protruding blade length adjusted into the cutter.

 **Caution** When handling the cutter blade, exercise care to prevent injury.

 **Note** When using the carrier sheet, use the standoff ring included with the Craft ROBO. Hold the clamp bracket tightly while attaching or removing the blade holder.

1. Turn the lock lever to the left (OPEN direction) and remove the blade holder.

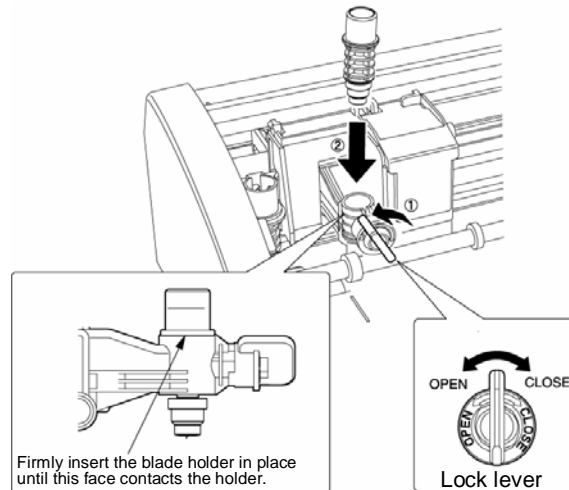

2. When using the carrier sheet, always use the standoff ring included with the Craft ROBO. Standoff ring compensates for the blade depth when using the carrier sheet. Attach the standoff ring to the blade holder before setting the blade holder in place.

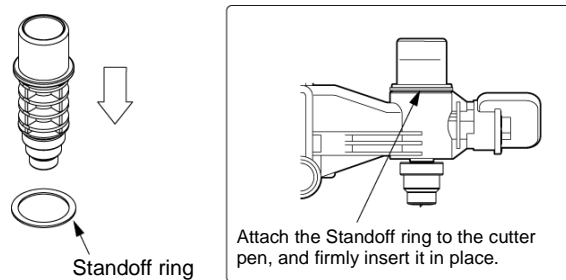

3. Insert the blade holder in the clamp bracket and turn the lock lever to the right (CLOSE direction).

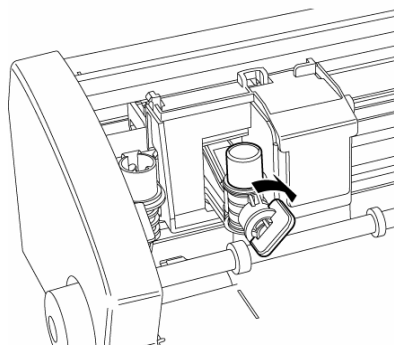

Ballpoint pen installation

The ballpoint penholder accepts cylinder pens up to 8.5 mm in diameter or hexagon shaped pens up to 7.5 mm side-to-side and whose tips extend between 3 and 3.5 mm past the ballpoint penholder's opening.

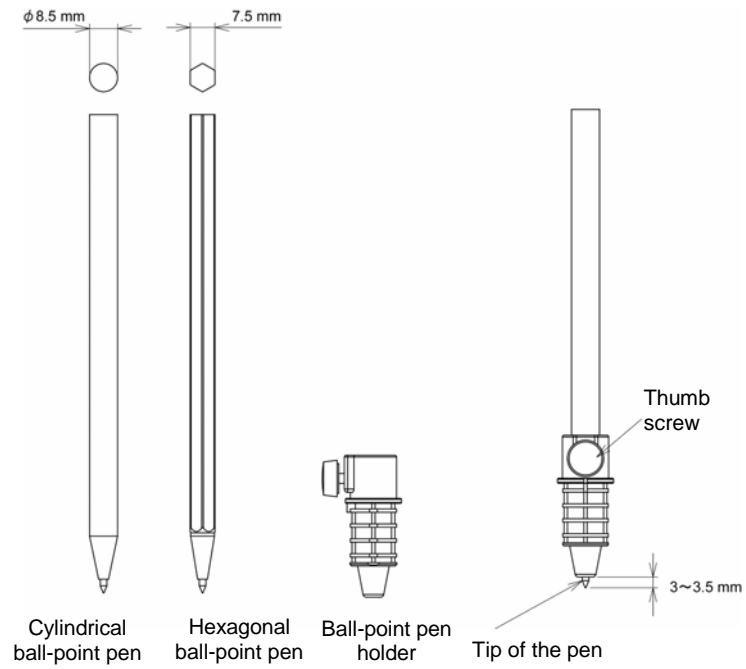

Installing the ballpoint pen

Set a ballpoint pen into the ballpoint pen holder and then into the clamp bracket.



When attaching the ballpoint pen holder, always align it with the notched part of the clamp bracket.

1. Loosen the thumbscrew by turning it counterclockwise.
2. Insert the ballpoint pen into the holder.
3. Confirm that the tip of the ballpoint pen protrudes from the holder 3 mm.
4. Tighten the thumbscrew by turning it clockwise.
5. Turn the lock lever to the left (OPEN direction)
6. Mount the ballpoint pen holder, making sure that the notched part of the holder aligns with the opening of the clamp bracket.

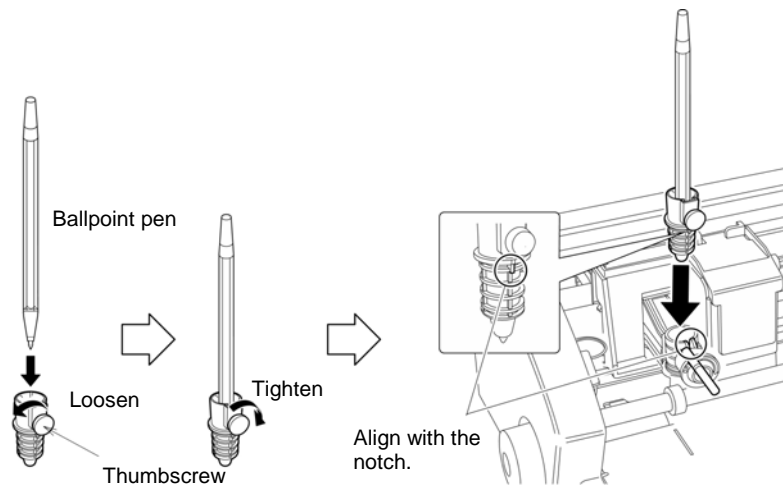

7. Once the penholder is in place, turn the lock lever to the right (CLOSE direction).

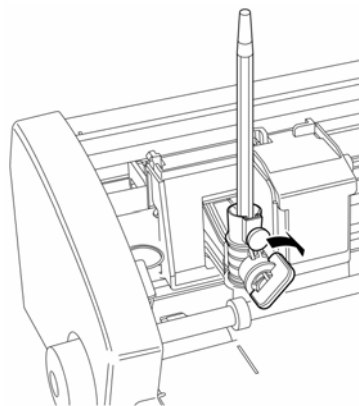

CHAPTER 3. CRAFT ROBO CONTROLLER

3.1 The Craft ROBO Controller

The Craft ROBO Controller is for controlling the Craft ROBO media selection and other settings, as well as test cut and other operations.



The term “media” as used in the body text of this manual refers to paper, film, and other materials to be cut or printed on.

3.2 Operating Environment

The following lists the minimum system requirements for the software to run.

- OS: Windows 98 Second Edition, Windows Me, Windows 2000, or Windows XP
- CPU: Pentium III 600 MHz or better
- Memory: 128 MB minimum (256 MB recommended)
- Monitor: Must be capable of 1024 x 768 High Color display (True Color recommended)
- Mouse
- CD-ROM drive



Please note that some of the images for the software used in this manual were prepared during the development stage. Therefore, the details displayed may differ from the actual ones. The functions and the placement of the settings are the same as the actual ones.

3.3 Installing the Craft ROBO Controller

Note Do not connect the Craft ROBO to your computer yet.

Starting up the Start window

Insert the CD included with the Craft ROBO into your computer; the “Start” window shown below will appear.

If this window does not appear, open My Computer and double-click on CD Drive.

If the “Start” window still does not appear, execute “MultiSetup.exe” on the CD-ROM.



When the “Start” window opens, click on “Install Craft ROBO Software and Driver.”

First, the installer of ROBO Master, the software used for printing and cutting images, is started up. When the installer of ROBO Master is finished or cancelled, the installer of the Craft ROBO Controller will be started up.

Installing the Controller

Installation procedure

- (1) When the installer starts up, the screen shown below is displayed first.



Click [Next] to proceed.

- (2) Next, a "Choose Destination Location" screen will be displayed.



Select the folder in which the Controller is to be installed.

Unless the folder shown by default does not have sufficient free space, it is not normally necessary to change it. If you do not want to change the default folder, click [Next] to proceed, otherwise click [Browse] and select desired destination folder.

(3) Next, a “Select Program Folder” screen will be displayed.

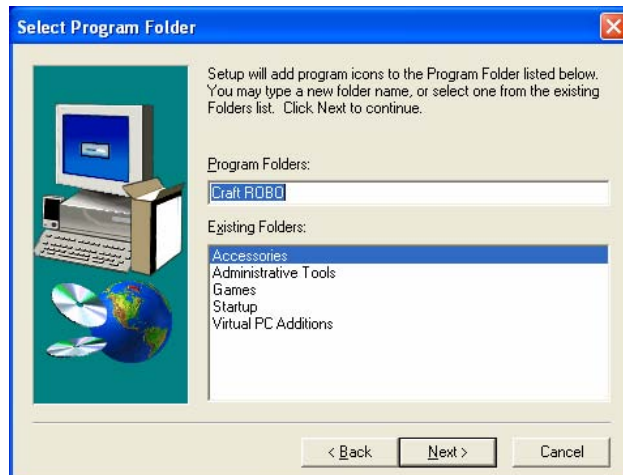

Select the program folder in which the program icon is to be placed.

To place the program icon in a new folder, enter a new folder name in “Program Folders.” To add the program icon to an existing folder, select one from the list of “Existing Folders.” A new folder named “Craft ROBO” is prepared by default; if this is unnecessary to change, click [Next]. File copying starts.

(4) When the system has finished copying files, a “Setup Complete” screen is displayed indicating that installation is complete.

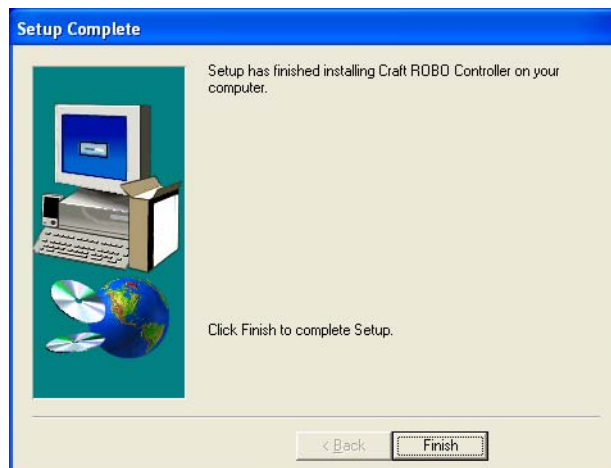

Click [Finish] to complete the installation. If necessary, install the Craft ROBO driver.

Follow the help displayed on the screen.

3.4 Using the Craft ROBO Controller

Starting up the Craft ROBO Controller

Check to confirm that the LED lamp of the Craft ROBO is lit. If it is not, press the Standby switch.

Check to confirm that the Craft ROBO and your computer are connected by a USB cable.

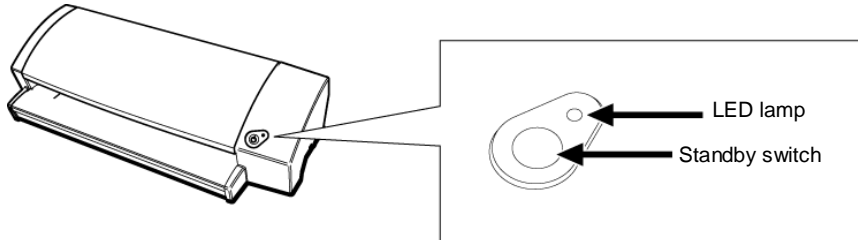

The Craft ROBO Controller can be started up in either of the following two ways:

(1) Starting up from the Windows Start menu or the shortcut

The Craft ROBO Controller can be started up from the Windows Start menu.

To start it up, select **“Start”** → **“(All) Programs”** → **“Craft ROBO”** → **“Craft ROBO Controller”**, assuming that program group name is **“Craft ROBO”**.

The Craft ROBO Controller can be also started up from the shortcut that is placed on the desktop.



(2) Starting up from ROBO Master

- (a) Click [Craft ROBO...] in the File menu of ROBO Master, or [Craft ROBO] icon on the toolbar.

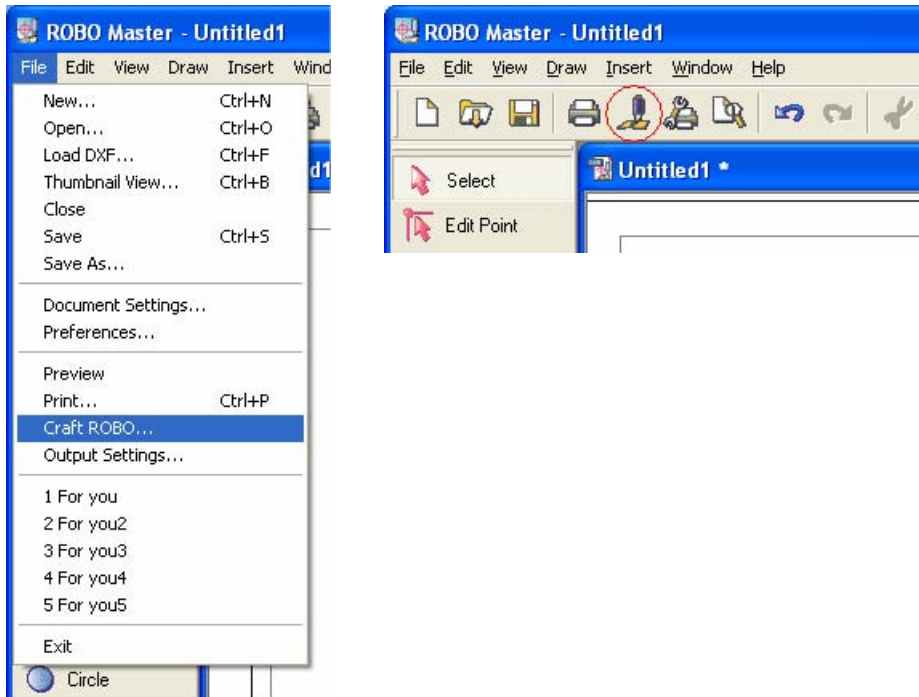

- (b) "Output to Craft ROBO" window will open. Click [OK] to start up the Craft ROBO Controller.

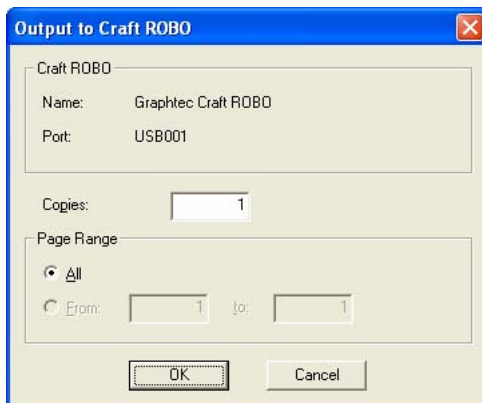

- (c) When the Craft ROBO Controller is started from the ROBO Master software, the [Cut] button is displayed, enabling output from the controller, otherwise it is replaced with [Close] button.

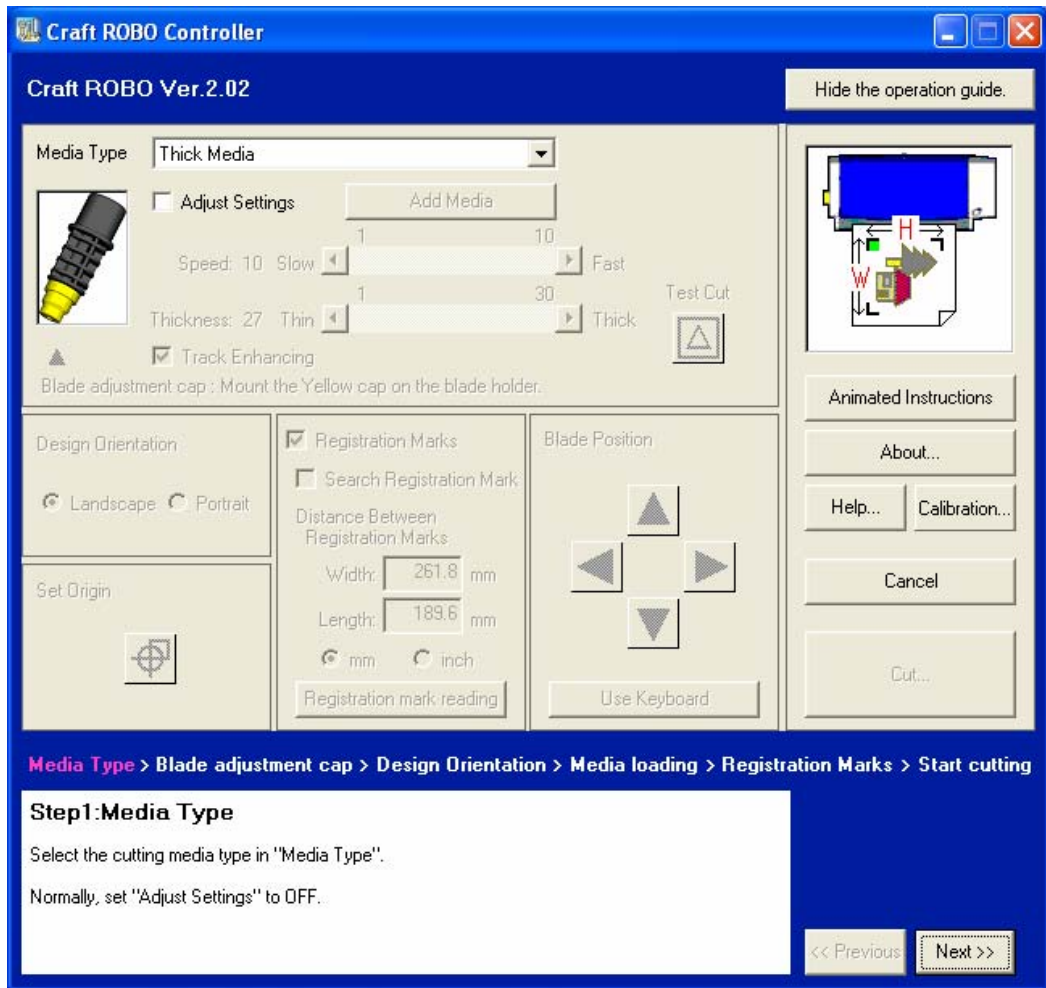

Note The [Cut...] and [Cancel] buttons are displayed only when the controller was started up from the ROBO Master software.

Cutter Operation

3.4.1 Test Printing

To reduce the waste of media, it is recommended to do a test plot when cutting design data for the first time or when changing the design data.

Test plot allows to visually confirm, by plotting cut lines with a ball pen, that they will be fully output and in a proper position.

1. Press the standby switch of the Craft ROBO to turn the LED lamp on.
2. Launch the Craft ROBO Controller from the Craft ROBO software. (See 3.4 Starting up the Craft ROBO Controller (2).)
3. Set Media Type to "Pen". (See 3.5.7 Media Type.)
4. Place a commercially available ballpoint pen in the provided ballpoint penholder and place it in the Craft ROBO.
5. Set the Design Orientation by referring to the cutter image in the upper right corner. (If the Controller is started from the ROBO Master, the Design Orientation is set automatically.) (See 3.5.10 Design Orientation.)
6. Load the media to the Craft ROBO.
7. If necessary, change the origin by using "Blade Position" and "Set Origin" Buttons. (See 3.5.8 Blade Position and 3.5.9 Set Origin.)
8. Press "Cut". The test print starts. (See 3.5.5 [Cut] Button.)

3.4.2 Performing a test cut and adjusting media settings



It is necessary to find appropriate cutting conditions by adjusting media settings and performing a test cut.

1. Press the standby switch of the Craft ROBO to turn the LED lamp on.
2. Launch the Craft ROBO Controller from the Windows Start menu or from the ROBO Master Software. (See 3.4 Starting up the Craft ROBO Controller.)
3. In "Media Type," select the media which seems to be the closest to the one to be used. (See 3.5.7 Media Type.)
4. Use the "Blade Position" function to move the pen to the position on the media where the test cut is to be performed. (See 3.5.8 Blade Position.)
5. Select the check box, "Adjust Settings." Conduct test cutting repeatedly while changing "Speed," "Thickness" and blade adjustment caps to identify the optimum conditions. (See 3.5.7-A Blade adjustment cap, 3.5.7-B Adjusting Settings, and 3.5.7-D Test Cut.)
6. Press the [Add Media] button, place the media and the color of the blade adjustment cap and press [OK]. The next and subsequent operations create the settings on the list for "Add Media." (See 3.5.7-E The [Add Media] button.)

3.4.3 Cutting Your Designs (Without Printing)

In ROBO Master software create a design composition, then draw the cutlines and open Craft ROBO Controller for cutting the cutlines.

1. Press the standby switch of the Craft ROBO to turn the LED lamp on.
2. Launch the Craft ROBO Controller from the Craft ROBO software. (See 3.4 Starting up the Craft ROBO Controller (2).)

3. Select media from “Media Type” drop-down list (See 3.5.7 Media Type.)
4. Replace the blade adjustment cap as prompted by graphical indicator. (See 3.5.7-A Blade Adjustment Cap.)
5. If cutting is not performed properly, adjust the cutting conditions. Select the check box “Adjust Settings.” Conduct test cutting while changing the settings such as “Speed,” “Thickness” and blade adjustment caps to find the optimal conditions. (See 3.5.7-A Blade adjustment cap, 3.5.7-B Adjust Settings, and 3.5.7-D Test Cut.)
6. Set the Design Orientation by referring to the image on the plotter. (If the Controller is launched from the ROBO Master, the Design Orientation is set automatically.) (See 3.5.10 Design Orientation.)
7. Load the media to the Craft ROBO.
8. If necessary, use “Blade Position” and “Set Origin” to change the point of origin. (See 3.5.8 Blade Position and 3.5.9 Set Origin.)
9. Press [Cut] to start cutting. (See 3.5.5 [Cut] Button.)

3.4.4 Printing and Cutting Your Design

In ROBO Master software set the registration marks, create a design composition, then draw the cutlines, print the design and open Craft ROBO Controller for cutting the cutlines.

The printout will contain both the registration marks and the design composition.

Cut the design as follows:

1. Press the Craft ROBO’s standby switch to turn the LED lamp on.
2. Launch the Craft ROBO Controller from the Craft ROBO software. (See 3.4 Starting up the Craft ROBO Controller (2).)
3. Select the media from “Media Type” drop-down list. (See 3.5.7 Media Type.)
4. Replace the blade adjustment cap as prompted by graphical indicator. (See 3.5.7-A Blade Adjustment Cap.)
5. If cutting is not performed properly, adjust the cutting conditions. Select the check box “Adjust Settings.” Conduct test cutting while changing the settings such as “Speed,” “Thickness” and blade adjustment caps to find the optimal conditions. (See 3.5.7-A Blade adjustment cap, 3.5.7-B Adjust Settings, and 3.5.7-D Test Cut.)
6. Set the Design Orientation by referring to the image on the plotter. (If the software is started up with ROBO Master, the Design Orientation is set automatically.) (See 3.5.10 Design Orientation.)
7. Load the media to the Craft ROBO.
8. Check to confirm that “Search Registration Mark” is on. (See 3.5.11-A Search Registration Mark.)
9. Press [Cut]. The registration mark is searched for and read. When it is properly read, continue with the cutting. (The procedure is successfully finished if cutting is started.) (See 3.5.5 [Cut] Button.)

If the system is unable to automatically read the registration marks

To read the registration marks with user’s assistance, perform the following two steps:

- (1) Search for the first registration mark and set it as origin. (The first registration mark is located at the lower left corner of the ROBO Master design area. It is shown in green on the illustration in the Craft ROBO Controller. (See 3.5.9 Set Origin))
- (2) Check the positions of the second and third registration marks using the first registration mark as a reference.

The registration marks can generally be designated manually, even if step (1) fails.

10. Turn off “Search Registration Mark” and move the pen to the first registration mark using the Blade

Position function. (The first registration mark is placed at the bottom left during the design stage and is shown in green on the illustration in the Craft ROBO Controller.) ([See 3.5.11-C Registration Mark Reading.](#))

11. Press the [Registration mark reading] button. It starts reading of the registration marks. ([See 3.5.11-C Registration mark reading](#))
12. When registration marks are found, press [Cut]. It starts cutting operation. If registration mark reading fails, reposition the media and return to Step 10.

3.5 Craft ROBO Controller Components

When the Craft ROBO Controller is launched, the following screen appears.

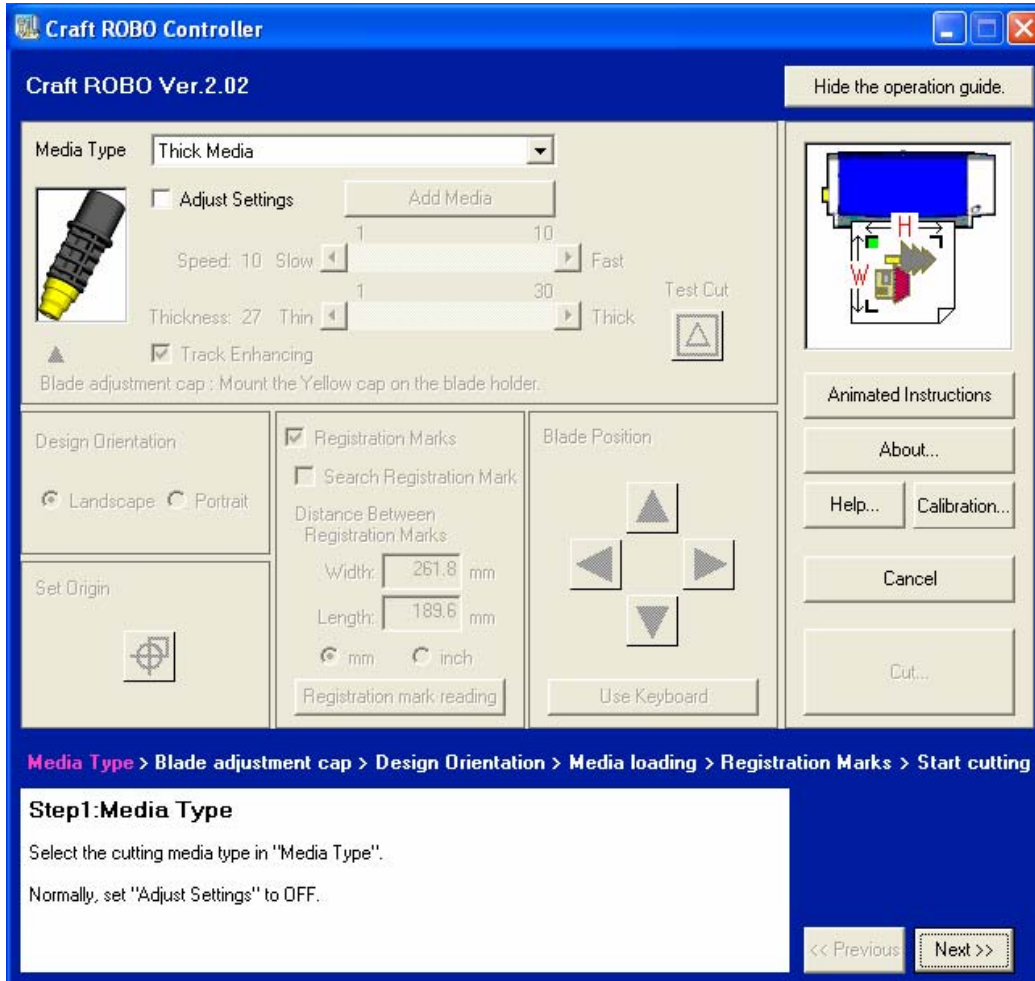

3.5.1 Hide/Show the operation guide

When the Craft ROBO Controller is launched, the operation guide is displayed at the bottom of the window. The [Hide/Display the Operation Guide] button turns the operation guide function on/off.

The operation guide provides step-by-step instructions for setting up and operating the Craft ROBO Controller.

3.5.2 [Animated Instructions] Button

The animated instruction describing operation of "Craft ROBO" and "Craft ROBO controller".

3.5.3 [Help] Button

Displays quick help

3.5.4 [About] Button

Displays the version information of the Craft ROBO Controller currently in use

3.5.5 [Cut] Button

Start cutting with the Craft ROBO. When the automatic reading of registration marks is specified, the registration marks are read first. When the registration marks have been read successfully, the Craft ROBO starts cutting.

3.5.6 [Cancel / Close] Button

Exits the Craft ROBO Controller.

3.5.7 Media Type Pull Down Menu



Media Type
Select the type of media to be cut. The setup items are listed below.

- | | |
|-------------|---|
| Thick Media | Select this item when paper thicker than 0.13 mm is used. |
| Thin Media | Select this item when paper thinner than 0.13 mm is used. |
| Pen | Select this item when the Craft ROBO with a pen (ballpoint pen) attached is used to draw a line. Use a pen (ballpoint pen) primarily for trial plotting before cutting. |

3.5.7-A Blade Adjustment Cap Indicator



For each media selected from “Media Type,” the Blade Adjustment Cap Indicator shows the color of the blade adjustment cap to be attached to the blade holder before cutting.

Blade adjustment cap color controls the blade length. The color selection depends on the thickness of the media to be cut.

3.5.7-B Adjust Settings

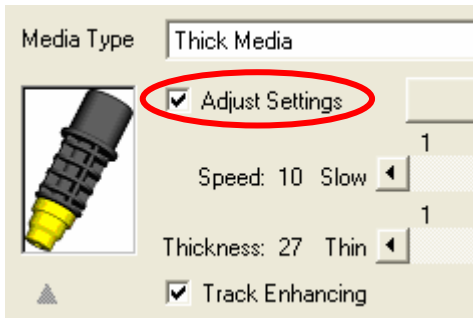

If the results of the test cutting indicate that the conditions need to be adjusted, select the “Adjust Settings” check box. As shown in the screen below, “Speed”, “Thickness”, “Test Cut” and “Add media” are displayed. They are disabled when the “Adjust Settings” box is not checked.

Speed: Adjusts the cutting speed.
 Selecting “Fast” increases the cutting speed, and selecting “Slow” reduces the speed.
 The slower the cutting speed, the higher the cutting quality.
 The speed can be adjusted in 10 steps.



Thickness: Specifies the thickness of the media to be cut.

3.5.7-C Track Enhancing

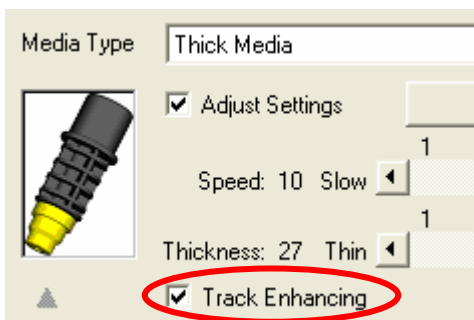

Track enhancing refers to the action of moving the media back and forth several times before cutting is started to improve the quality of cutting. It is performed automatically when the thickness exceeds a certain value. Keep this function on during normal use. This function may be turned off to reduce the track imprinting on the media provided you have verified that cutting is performed normally.

3.5.7-D Test Cut

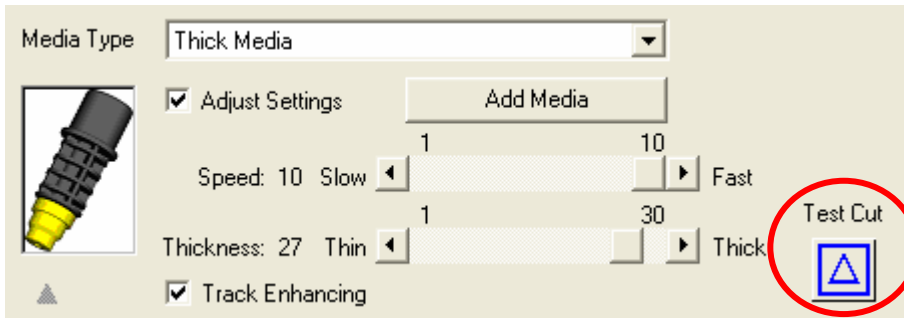

Use the [Blade Position] button to move the blade to the position at which test cutting is to be performed, and click [Test Cut]. A 10 mm x 10 mm test pattern will be cut.

The cutting conditions are appropriate when the results of test cutting indicate that the media is fully cut with a slight trace of cutting on the backing material (either liner or carrier sheet). If cutting is not properly done, such as when the backing material is cut or the media is not cut perfectly, adjust the degree to which the cutter blade protrudes. Alternatively, change the parameters in “Media Type” or change the “Thickness” setting.

The quality of the cutting results varies depending on the media to be cut and other conditions. To cut media with which you are not experienced, always perform test cutting.

3.5.7-E [Add Media] Button

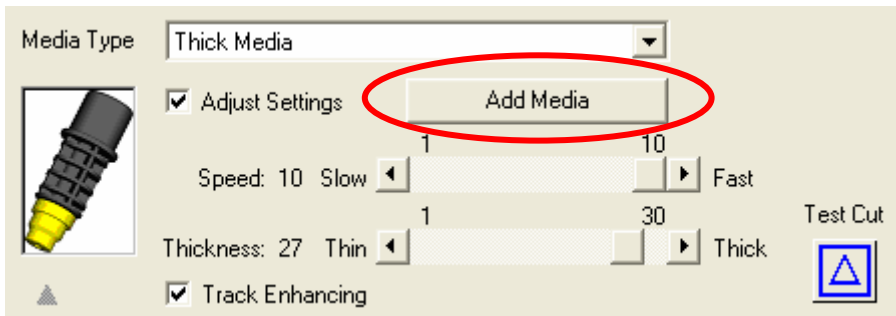

Clicking on “Add Media” button opens the “Add media” window. Custom media type can be created by entering its settings and name.

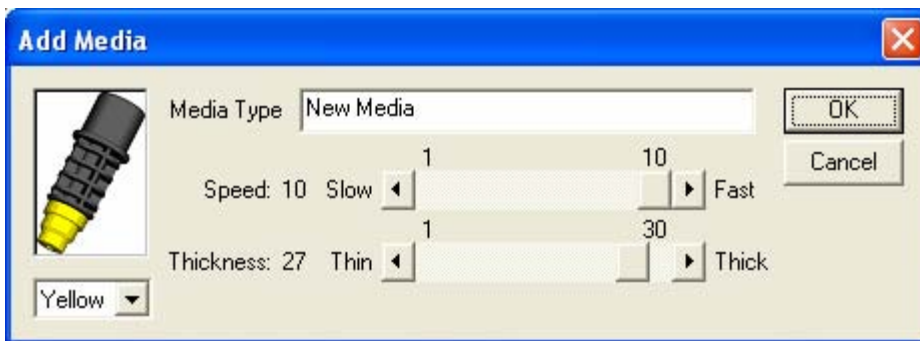

3.5.8 Blade Position

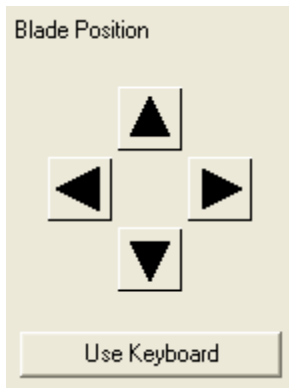

Moves the position of the blade or the pen (ballpoint pen) of the Craft ROBO. When the left-hand or right-hand buttons are pressed, the pen (ballpoint pen) or the blade is moved to the left or right. When the up or down buttons are pressed, the media is moved. Clicking the [Use Keyboard] button allows the arrow keys on the keyboard to be used in the same way as the [Blade Position] button.

3.5.9 Set Origin

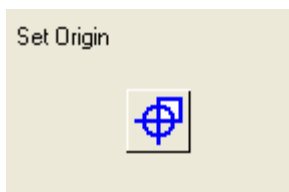

Use this button to specify the origin position of the cutting area. After moving the pen (ballpoint pen) or blade to the origin position using the [Blade Position] buttons, click the [Set Origin] button and set current position to be specified as the origin. Do not use this function while using registration marks. Registration marks allow finding the origin position automatically.

When cutting/plotting is performed with the media orientation set to landscape, when registration marks are used, origin is set at a position near the red circle in the diagram below. If the media orientation is set to portrait, origin is set at a position near the blue circle in the diagram below.

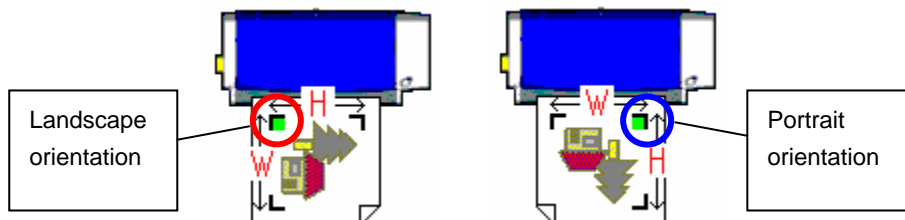

Note: Consider the size of the design to be cut while moving the origin. If the position of the origin is not set correctly, part of the design may be cut/plotted off the media, as shown below.

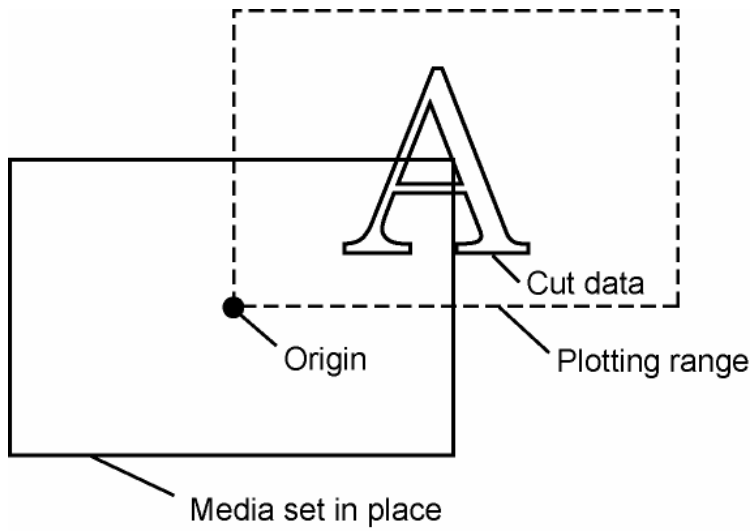

Note: The Set Origin function cannot be used while the check box "Alignment" is selected.

3.5.10 Design Orientation

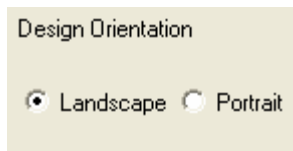

Select "Landscape" for a design where the media is positioned horizontally and "Portrait" where the media is positioned vertically.

The orientation is automatically set when output is performed from the ROBO Master.

When Landscape or Portrait is selected, the width or height of the illustration in the Craft ROBO Controller also changes.

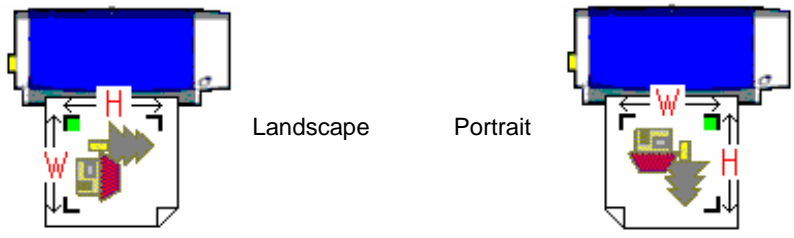

3.5.11 Registration Marks

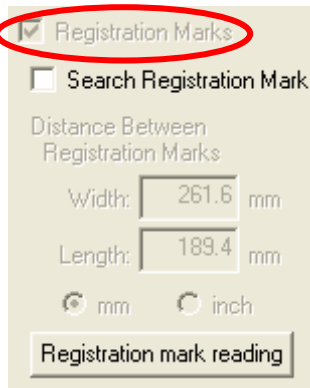

When it is called up from the ROBO Master, if registration marks are set for a document in the ROBO Master, this parameter is automatically turned on and cannot be changed. This setting is used for cutting printed design that has registration marks already printed.

When the check box, "Registration Marks," is selected, the reading of registration marks is enabled.

3.5.11-A Search Registration Mark

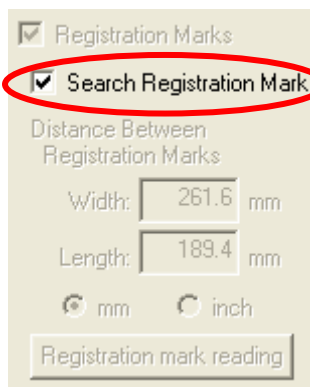

Craft ROBO has a function for automatically reading registration marks (*).

Keep this function on during normal use.

When the function for reading the registration marks is on, the registration marks are automatically searched for and read right before cutting. When the registration marks are read normally, cutting is performed.

The function for reading the registration marks automatically searches for the registration marks within a fixed range from the current position of the blade/pen towards the center of the media. The registration marks may not be automatically found if they are not located in a place that is generally used. In this case, turn off the function and perform user-controlled reading of the registration marks.

(See 3.5.11-C [Registration Mark Reading] for user-controlled reading of registration marks.)

*Registration marks

Registration marks are used for aligning the printed design with embedded cutlines. Registration marks are printed along with the design and Craft ROBO reads them with its registration mark sensor, thus assuring alignment of printed images and cutlines.

The registration marks are shaped like corners of a rectangle and are located at three corners surrounding the image to be printed.

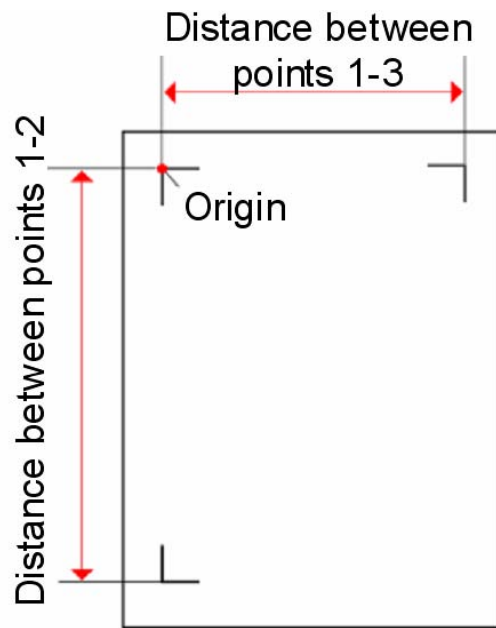

Note

When registration marks are used, avoid placing them on or in the vicinity of the printed image as much as possible. When registration marks are used, it is also recommended to use an ink-jet printer. If a laser printer is used for output, the printed media may be distorted by heat, resulting in a misaligned cutting.

3.5.11-B Distance between Registration Marks

Registration Marks
 Search Registration Mark
Distance Between Registration Marks
Width: mm
Length: mm
 mm inch

These controls are displayed when Search Registration Marks is turned off.

The distance between the registration marks is the distance from one corner of a registration mark to the corner of the other registration mark.

In most cases, this is automatically set from ROBO Master or an application that is able to perform this function.

3.5.11-C Registration Mark Reading

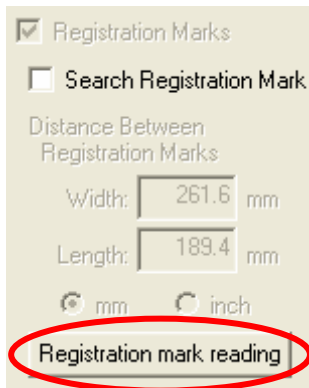

This is displayed when Search Registration Marks is turned off. It starts manual reading of the registration marks.

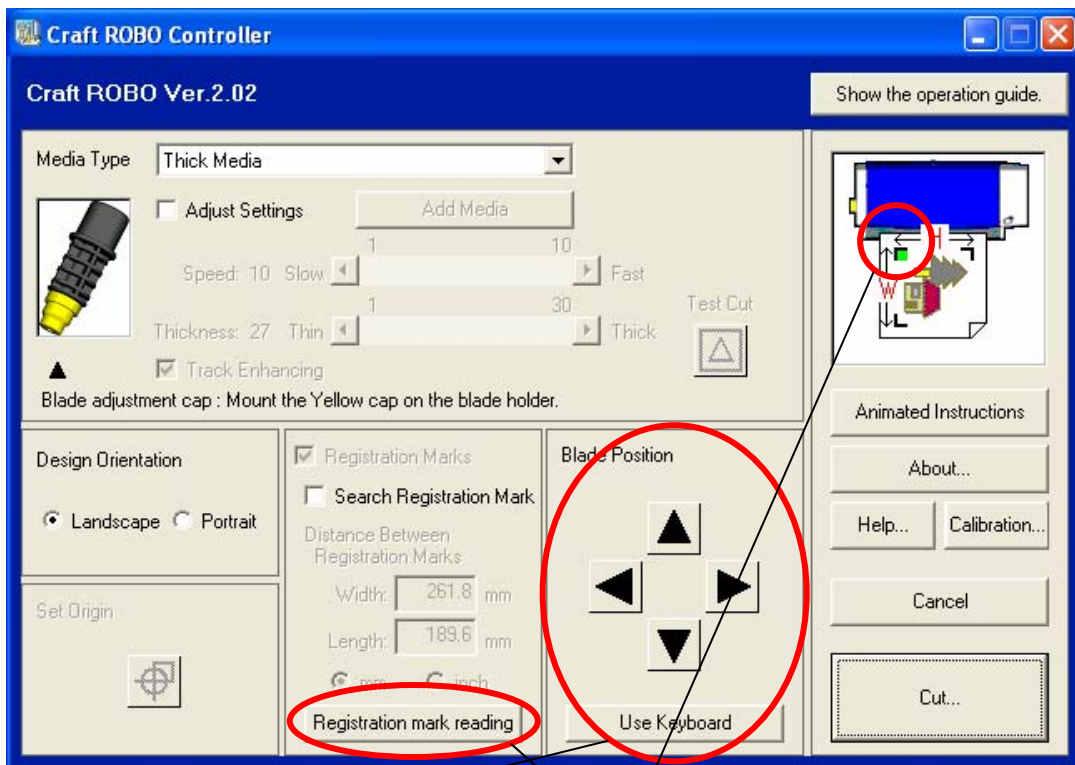

(1) Use the [Blade Position] button to move the blade to within the range of the registration mark.

The range of the registration mark is displayed as a green rectangle in the illustration at the upper right corner of the Controller. The range of the registration mark position may change based on the orientation of the design.

(2) After performing Step (1), click on the [Registration Mark Reading] button. It starts manual reading of the registration marks.

Note: When the registration marks have been read, it becomes impossible to operate the [Registration Marks] group box and [Design Orientation]. In addition, the [Calibration] button is disabled.

To enable operation again, turn the Standby switch of the Craft ROBO off, then on again.

3.5.12 Calibration

Click [Calibration] to open the Calibration window. Calibration function allows to re-calibrate the registration mark sensor.



If the “Read Registration Marks” function in the “Use Registration Marks” section of the controller menu has been used, [Calibration] cannot be used. In such a case, temporarily turn off the Standby switch of the Craft ROBO and then turn it on again.

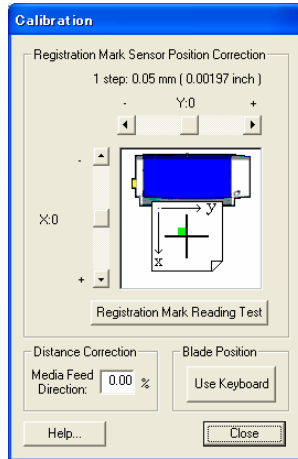

3.5.12A Registration Mark Sensor Position Correction

This function is for adjusting the cut position when the printed image and the cut position are misaligned. This operation can adjust Incorrect reading of the registration marks.



It is normally not necessary to perform this correction.

Follow the procedure described below to perform Registration Mark Sensor Position Correction.



To perform a Registration Mark Reading Test, select Letter -size matte white paper and install the pen into the Craft ROBO.

- (1) Install the pen into the Craft ROBO.
- (2) For the “Registration Mark Reading Test,” use paper with a cross drawn on it. Follow the procedure described below to prepare a sheet of paper with a cross drawn on it.

Drawing a cross

Draw a cross with black lines 0.5 mm to 1 mm thick and at least 40 mm in length. The two lines must intersect each other at right angle within the print area of the media. Make sure the vertical and horizontal lines are as parallel to the edges of the media as possible.

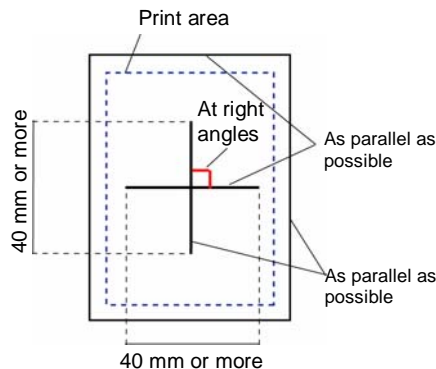

- (3) From the “Media Type” drop-down box of the Craft ROBO Controller, select the item corresponding to the media used in the “Registration Mark Reading Test.”
- (4) When you have finished preparing the “Test paper for the Registration Mark Reading” and loaded it into the Craft ROBO, open the “Calibration” window and move the pen to the green square part of the diagram.

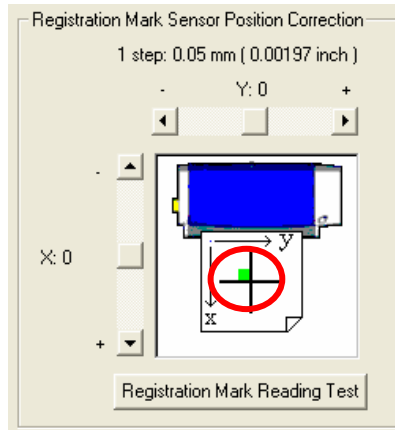

You can click [Use Keyboard] in the “Blade Position” section of the Controller, and use the arrow keys on the keyboard to move the cutter.

- (5) Click [Registration Mark Reading Test]. After reading the printed cross, the pen will draw a cross.

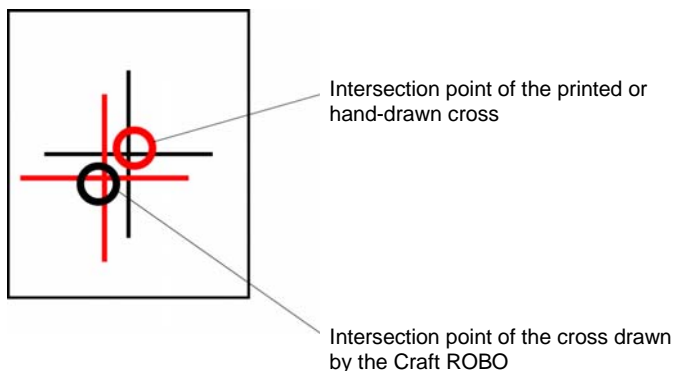

If the position of the intersection point recognized by the Craft ROBO is not aligned with that of the printed cross, correct it as specified below.

Use the vertical (y) or horizontal (x) scroll bar to set a correction value.

The correction value must be in the range of –40 to 40.

One step represents 0.05 mm. For example, if 20 is specified as the correction value, the line drawn by the pen (ballpoint pen) moves 1 mm.

If the position of the intersection point recognized by the Craft ROBO is not aligned with that of the printed cross, set a correction value in accordance with the figures shown below. The red circle in the diagram denotes the position of the intersection point plotted by the Craft ROBO.

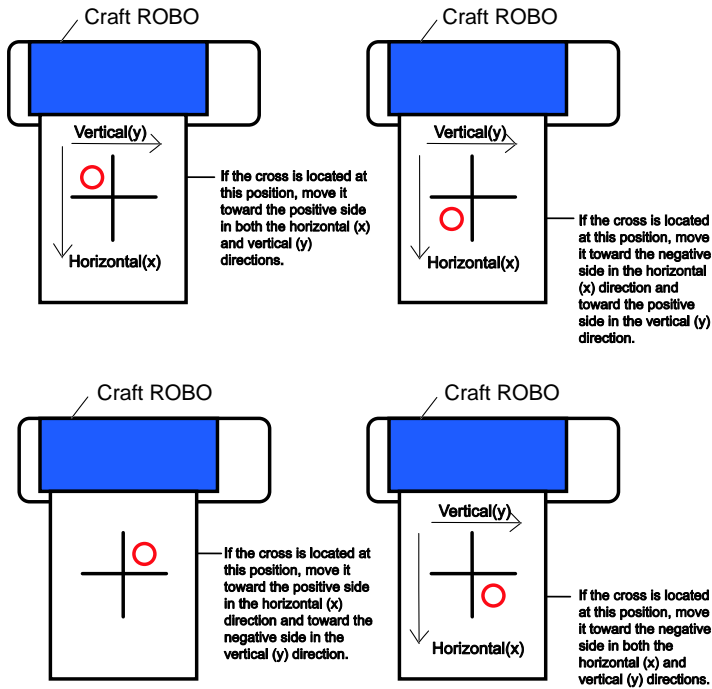

3.5.12B Distance Correction

When the Craft ROBO moves the media, the distance by which the media is fed may not always be exactly as expected, depending on media thickness and cutting speed. Distance Correction is used to account for such an error.

In the range of -2% to $+2\%$, enter a negative value if the fed distance is greater than the expected distance, or a positive value if the fed distance is less than the expected distance.

The correction value may be calculated from the equation below.

$$1 - \frac{\text{actually moved distance}}{\text{distance to be moved}} \times 100 = \text{correction value}$$

Concrete example If the media needs to be moved 500 mm and the distance actually moved by the Craft ROBO is 495 mm, then
 $(1 - 495 \div 500) \times 100 = 1$
 Therefore, enter the value 1 for correction.



Note It is not normally necessary to perform correction. When registration marks are used, correction is performed automatically.

3.6 Messages

The USB port is currently in use. Please wait ten seconds, and then try again.

Cannot communicate with the Craft ROBO. Check that the USB cable is connected correctly, press the Craft ROBO's standby switch, and then confirm that the LED is lit.

Craft ROBO communication error. Press the standby switch twice.

→ Follow the instructions in the message.

GITKUSBP.DLL could not be found, and so the Craft ROBO Controller could not be started. Please reboot your computer or re-install the Craft ROBO Controller.

The GITKUSBP.DLL functions could not be found, and so the Craft ROBO Controller could not be started. Please reboot your computer or re-install the Craft ROBO Controller.

→ Follow the instructions in the message.
To install the software again, first uninstall the Craft ROBO Controller currently installed. If the problem is not solved, download the latest version of the Craft ROBO Controller from the Craft ROBO website and install it.

The value specified for the horizontal distance between the registration marks exceeds the specifiable range.

Please specify a distance in the range 0 to 970.0 mm.

→ Follow the instructions in the message.

Registration mark reading failure. Please reload the medium.

→ Registration mark reading failed.
Turn off the standby switch of the Craft ROBO, reset the media and turn the standby switch on again.

The Craft ROBO Controller is already active. Please shut the controller down and perform the operation once again.

→ This message is displayed when you duplicate starting up the Craft ROBO Controller. Exit the currently operating Craft ROBO Controller and restart it to continue operation.

Appendix A. Standard Specifications

Item	Specification
Feeding method	Grit-rolling
Drive	Stepping motor
Cutting range	Maximum: 200 mm x 1000 mm (in expanded mode)
Effective sheet width	A4 size supported Loadable sheet width: maximum 260 mm, minimum 210 mm unless the carrier sheet is used
Operating speed	10 - 100 mm per second (10 steps of 10 mm per second per step)
Loadable number of blades/pens	1 pc.
Tools	Blade with dedicated blade holder General-purpose ballpoint pen (used only with the ballpoint penholder)
Media types that can be cut	Film Media 0.1 mm or less in thickness, liner-included thickness of 0.3 mm or less Inkjet or laser paper (up to 157 g/m ²) Drawing paper, postcard * Not all types of media can be cut.
Interface	USB 1.1 (USB 2.0 compatible)
Rated power supply	Dedicated adapter, 24 V DC (1.875 A)
Power consumption	25 W (10 W or less during standby)
Working environment	5 ° - 40 °C, 35 to 80% R.H. (No condensation)
Guaranteed operating environment	16° - 32° C, 35 to 70% R.H. (No condensation)
External dimensions (W x D x H) (mm)	Approx. 368 x 160 x 105 mm (not including the feed knob)
Weight	Approx.2.5 kg.

INDEX

- A**
- AC adapter jack 1-2
- B**
- Ballpoint pen installation 2-11
- Ballpoint penholder 1-2
- Blade adjustment caps and media selection.. 2-9
- Blade holder 1-2
- Blade holder description 2-8
- C**
- Carrier sheet 2-5, 2-6, 2-7
- Changing the blade adjustment caps 2-9
- Check all the items 1-1
- Clamp bracket 1-2
- Connecting the Power Adapter 2-1
- Connecting to a Computer 2-1
- Craft ROBO Controller Components 3-11
- [About] Button 3-12
- [Animated Instructions] Button 3-11
- [Cancel / Close] Button 3-12
- [Cut] Button 3-12
- [Help] Button 3-11
- Blade Position 3-15
- Calibration 3-20
- Distance Correction 3-22
- Registration Mark Sensor Position
 Correction 3-20
- Design Orientation 3-16
- Hide/Show the operation guide 3-11
- Media Type Pull Down Menu 3-12
- [Add Media] Button 3-14
- Adjust Settings 3-13
- Blade Adjustment Cap Indicator 3-12
- Test Cut 3-14
- Track Enhancing 3-13
- Registration Marks 3-17
- Distance between Registration Marks .. 3-18
- Registration Mark Reading 3-19
- Search Registration Mark 3-17
- Set Origin 3-15
- Craft ROBO Parts and Functions 1-2
- Cutter Operation 3-8
- Cutting Your Designs 3-8
- If the system is unable to automatically
 read the registration marks 3-9
- Performing a test cut and adjusting media
 settings 3-8
- Printing and Cutting Your Design 3-9
- Test Printing 3-8
- Cutting area 2-4
- Cutting area of the carrier sheet 2-7
- Cutting Head 1-2
- Cutting mat 1-2
- F**
- Feed knob 1-2
- G**
- Guideline 1-2
- I**
- Installing the ballpoint pen 2-12
- Installing the blade holder 2-10
- Installing the Controller 3-3
- Installing the Craft ROBO Controller 3-2
- L**
- LED lamp 1-2
- Letter Size media 2-6
- Loading Media 2-2
- Loading Method 2-2
- M**
- Media roller 1-2
- Media Size 2-3
- Messages 3-23
- O**
- Operating Environment 3-1
- P**
- Pinch roller 1-2
- S**
- Setting the Blade Length 2-8
- Smaller than Letter Size media 2-5
- Standby switch 1-2
- Starting up the Craft ROBO Controller 3-5
- Starting up the Start window 3-2
- T**
- The Craft ROBO Controller 3-1
- U**
- USB interface connector 1-2
- Using the carrier sheet 2-5
- Using the Craft ROBO Controller 3-5
- W**
- When the Media warps up 2-3
- Work surface 1-2

- The information contained herein is subject to change without notice.

CC100 User's Manual (CC100m-UM-152)	Issued 1st edition	November 9, 2004 000
--	-----------------------	-------------------------

Issued by Graphtec Corporation
503-10 Shinano-cho, Totsuka-ku, Yokohama, Japan